

# Prestressed Hollowcore

Concrete Flooring Systems' prestressed hollowcore is an extruded concrete element with continuous voids provided to reduce the self weight and provide an efficient structural section.

## THE BENEFITS OF HOLLOWCORE FLOORS

### Rapid Construction

Hollowcore slabs are cut to lengths to suit the building design before leaving the factory, resulting in safe and speedy construction and reduced cost.

### Working Deck

Hollowcore slabs provide an immediate working deck for other trades once grouted.

### Long Span

Hollowcore slabs achieve long spans, resulting in flexible open space with fewer beams, walls and supporting columns.

### No Formwork or Propping

Expensive formwork and temporary props are eliminated.

### High Load Capacity

Hollowcore floors can support the heavy loads required in most factories, warehouses and storage buildings

### Fire Resistance

All slabs have a 1 hour fire resistance. This can however be enhanced up to 4 hours.

### Holes for Services

Holes can be preformed to accommodate services, dependant on size and location. For further details contact our technical department.

## Section profiles and depths

A typical example of our section profile is detailed below. Concrete Flooring Systems' slab range from 150mm to 300mm

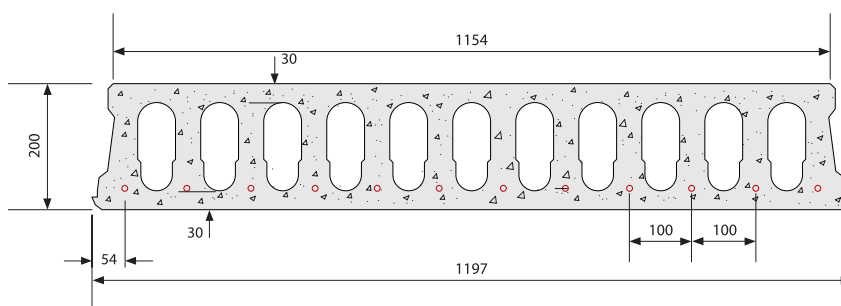

## Structural Performance

A general guide on performance characteristics can be seen in the table below

Unit Depth (mm)	Self Weight (kN/m <sup>2</sup> )	Applied Load (kN/m <sup>2</sup> )/Limiting Clear Span (m)					
		1.5kN/m <sup>2</sup>	3.0kN/m <sup>2</sup>	4.0kN/m <sup>2</sup>	5.0kN/m <sup>2</sup>	7.5kN/m <sup>2</sup>	10.0kN/m <sup>2</sup>
150	2.5kN/m <sup>2</sup>	6.50	6.50	6.00	5.70	5.00	4.50
200	3.0kN/m <sup>2</sup>	8.00	8.00	7.80	7.40	6.50	5.80
250	3.6kN/m <sup>2</sup>	10.60	9.80	9.30	8.80	7.80	7.20
300	4.1kN/m <sup>2</sup>	12.00	11.50	10.80	10.30	8.80	8.00

N.B.

1. It is assumed that units have 100mm end bearing - For spans greater than 9m increased bearing is recommended.
2. No allowance has been made for loading other than that specified.
3. No allowance has been made for service openings.

All Hollowcore floor slabs are designed in accordance with BS8110:(1997) The Structural Use of Concrete

Hollowcore slabs are designed to have effective shear key joints between adjacent slabs such that when grouted the individual slabs become a system that behaves similarly to a monolithic slab.

Prestressed Hollowcore slabs will exhibit an upward camber, the degree of which will depend upon the span and amount of prestressing force applied. Due allowance must be made for this in determining finishes and overall floor thicknesses.

Diaphragm action is sometimes required from a floor slab in order to transmit horizontal force to the primary supporting structure. Hollowcore slabs may be used efficiently to produce a diaphragm either with or without a composite structural topping. Various connection details are available to provide the interaction between the floor and primary structure